

CDF experimental results on diffraction

Michele Gallinaro

(on behalf of the CDF collaboration)

October 29, 2008

- Introduction
- Diffractive production (dijets, W/Z, Forward jets)
- Exclusive production (dijets, $\gamma\gamma$, ee)
- Conclusions

Hadronic diffraction

Elastic and diffractive processes

⇒ leading hadron emitted at small angle

The exchange (“pomeron”) is colorless

⇒ large rapidity gap

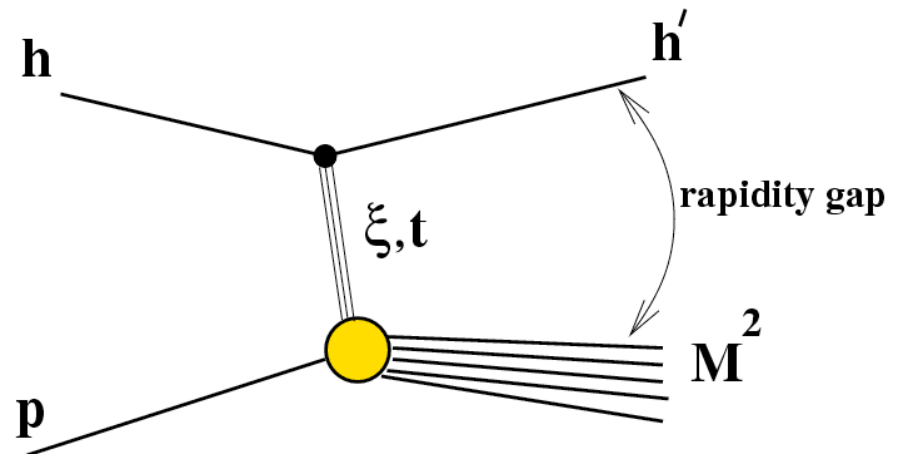

Introduction

- In diffraction no quantum numbers are exchanged

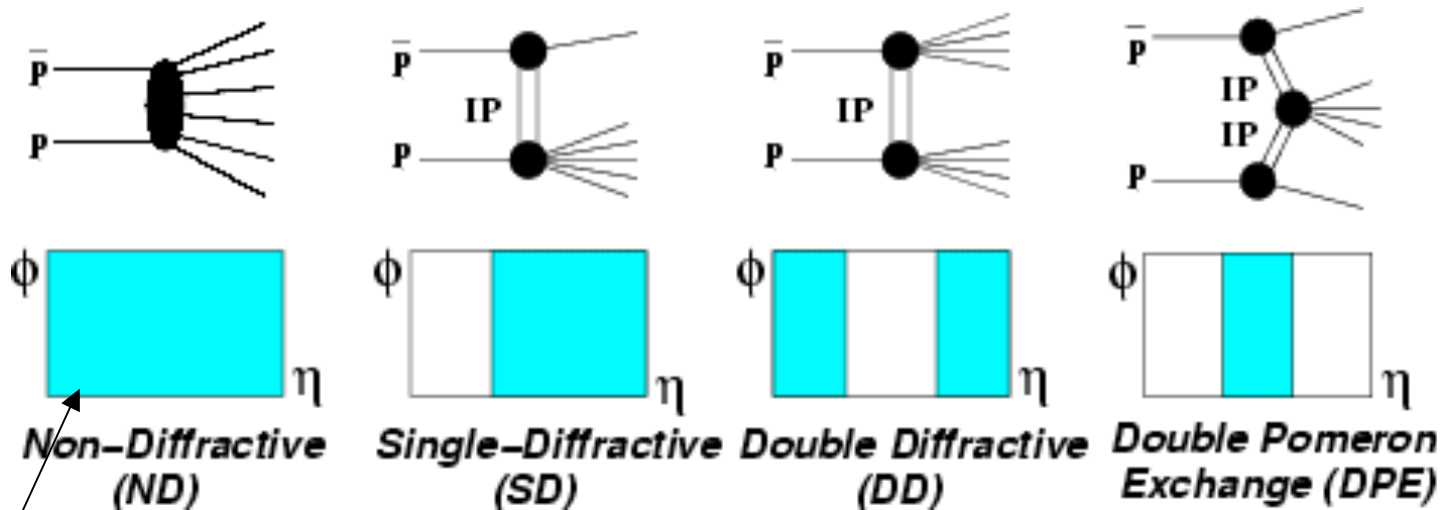

Shaded area corresponds to particle production

CDF central and forward detectors

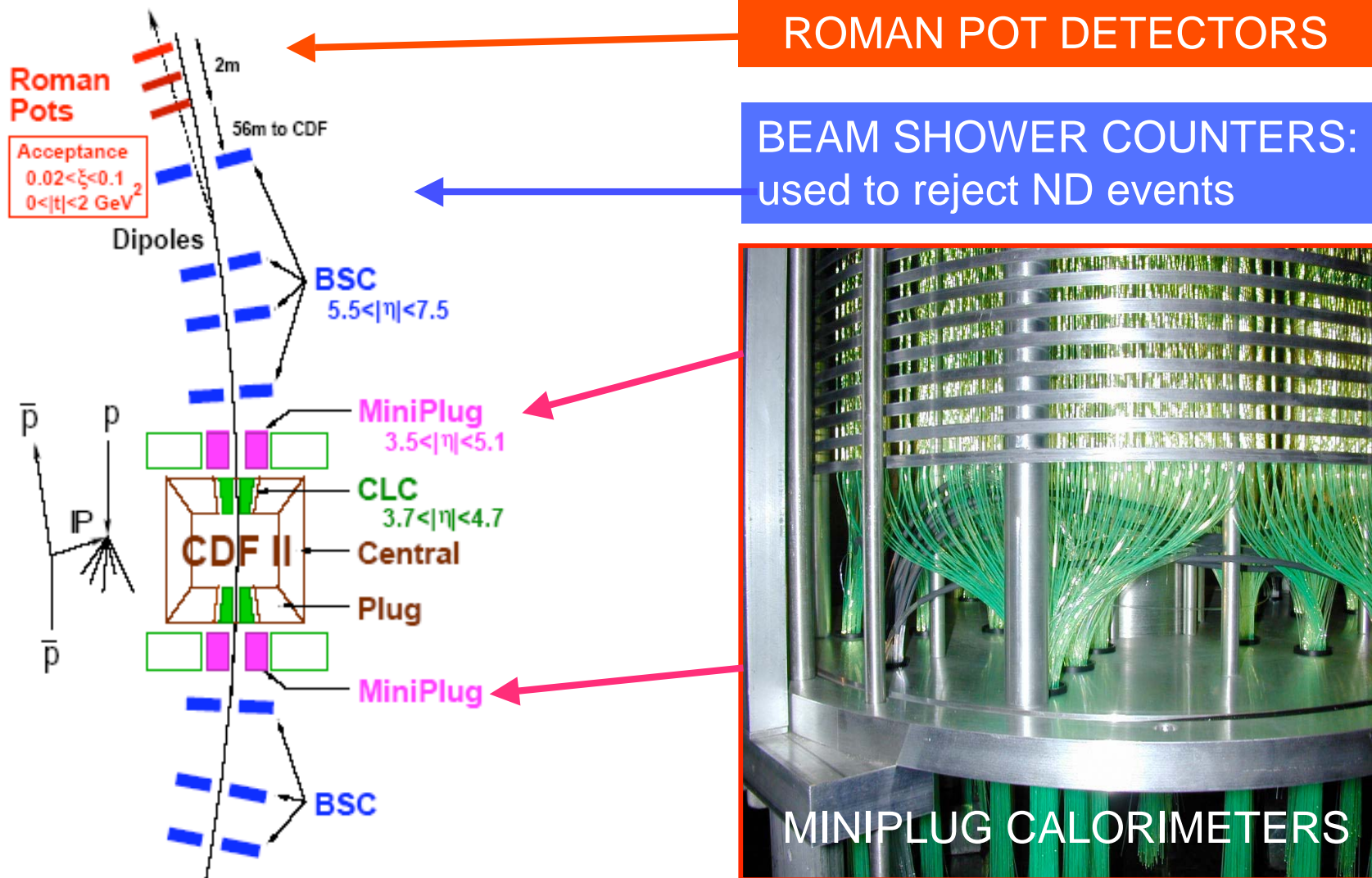

Diffractive dijets

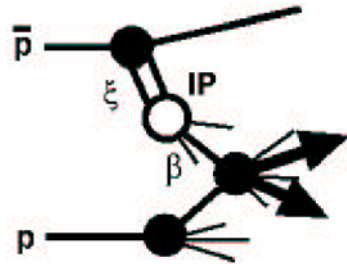

ξ : fraction of anti-proton momentum loss
 β : fraction of pomeron momentum carried by parton
 parton $x_{Bj} \equiv \beta \cdot \xi$

$$x_{Bj} = \frac{\sum_{jet} E_T \cdot e^{-\eta}}{\sqrt{s}}$$

Measure SD/ND ratio of dijet rates

$$\frac{\sigma(SD_{jj})}{\sigma(ND_{jj})} = \frac{F_{jj}^D(x)}{F_{jj}(x)} \quad (\text{LO QCD})$$

CDF Run I result suppressed
 by factor of ~ 10 relative to HERA

\Rightarrow breakdown of QCD factorization

Discrepancy can be attributed to additional
 color exchange which spoil the gap formation

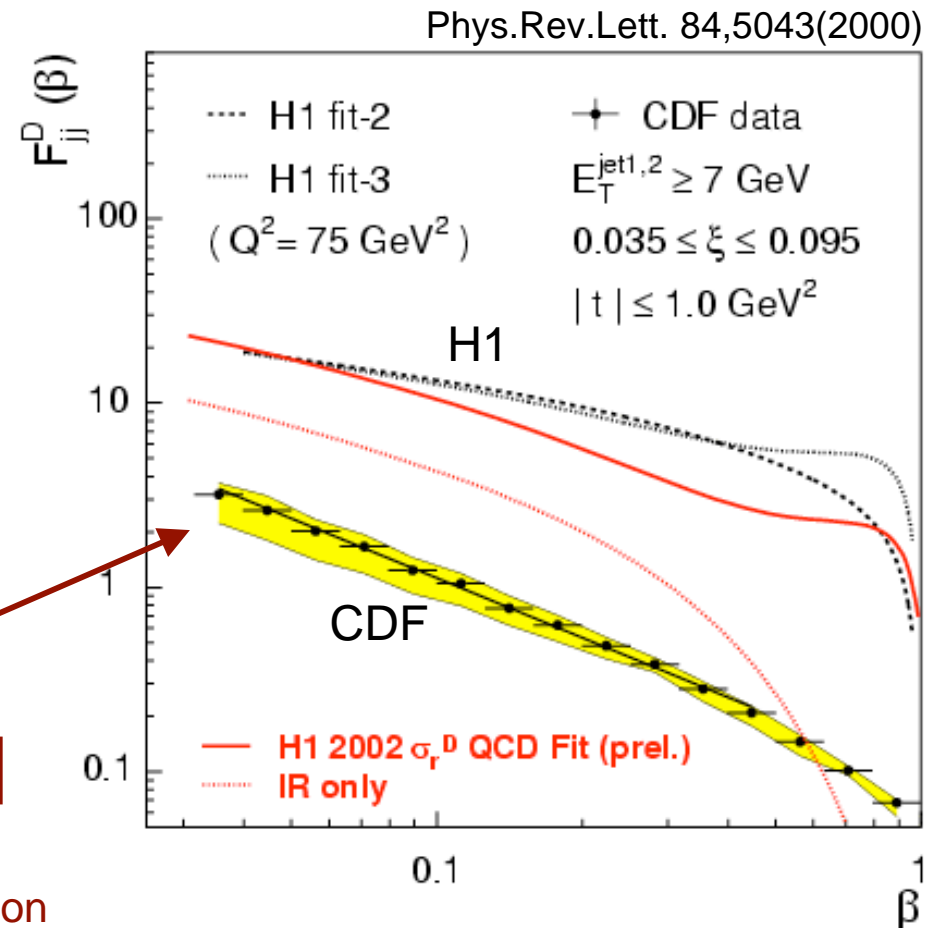

Restoring factorization

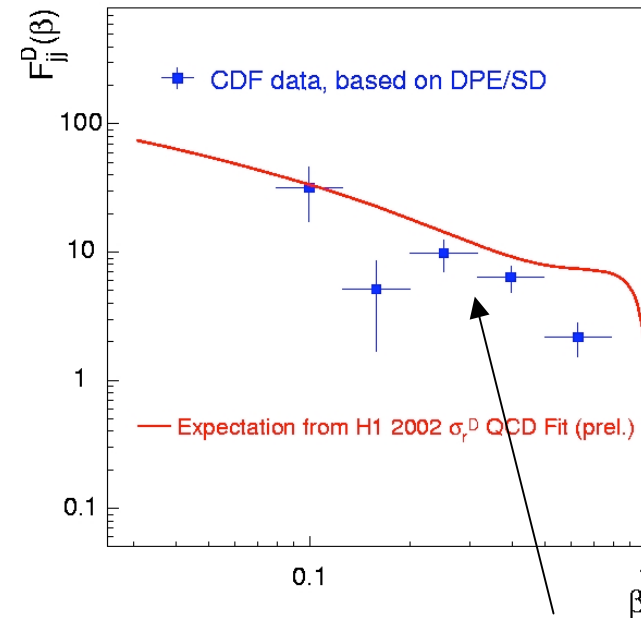
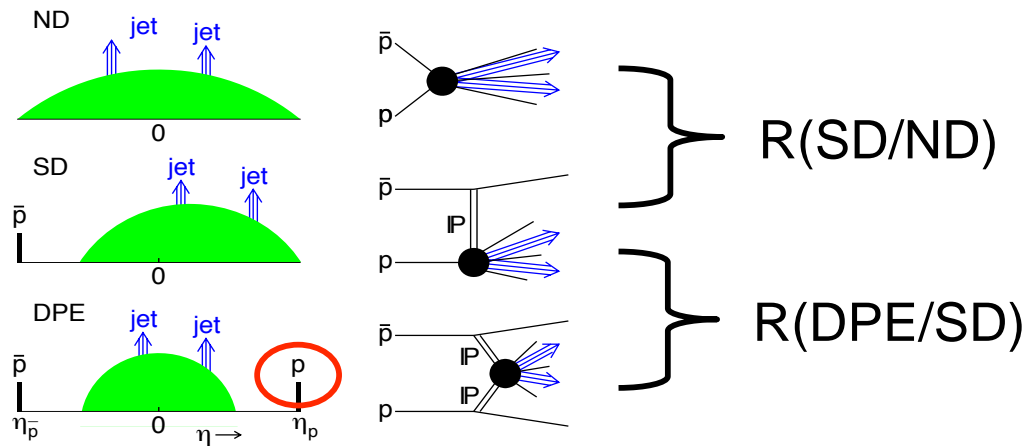

factorization is restored !

The diffractive structure function measured using DPE events is approximately the same as the one expected from HERA

Event selection in Run II

ξ : momentum loss fraction of pbar

$$\xi = \frac{\sum_{(\text{all towers})} E_T e^{-\eta}}{\sqrt{s}}$$

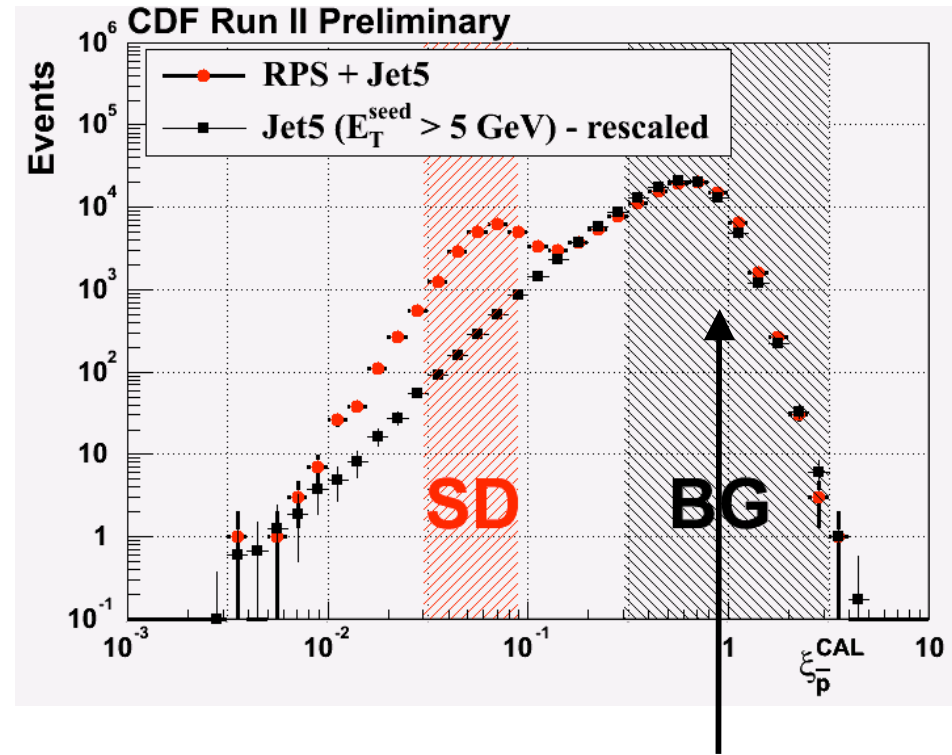
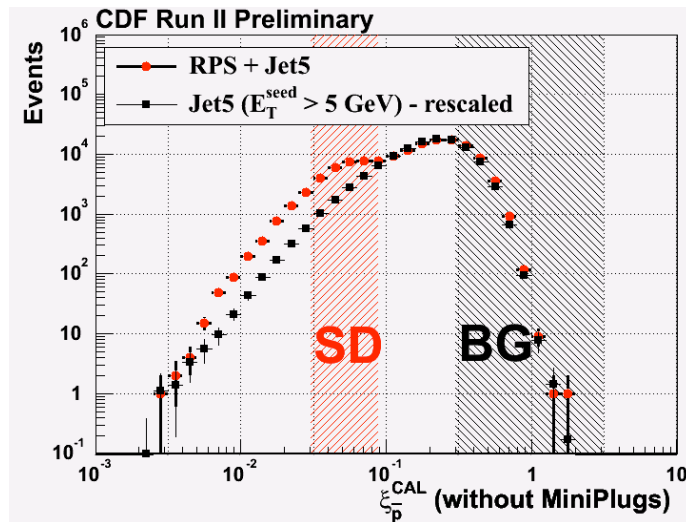

overlap events
(multiple $p\bar{p}$ interactions)

MP energy scale: $\pm 30\% \rightarrow \Delta \log \xi = \pm 0.1$
 RP acceptance ($0.03 < \xi < 0.09$) $\sim 80\%$

Multiple interactions in Run II

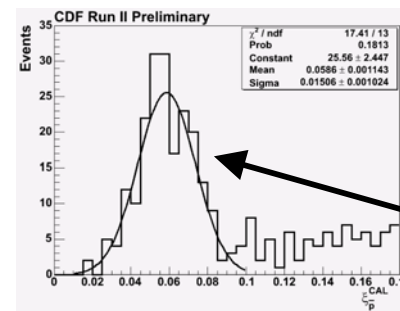
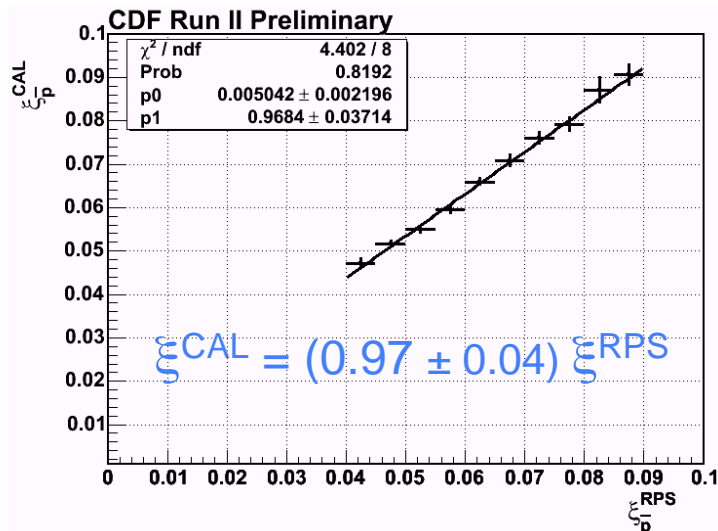
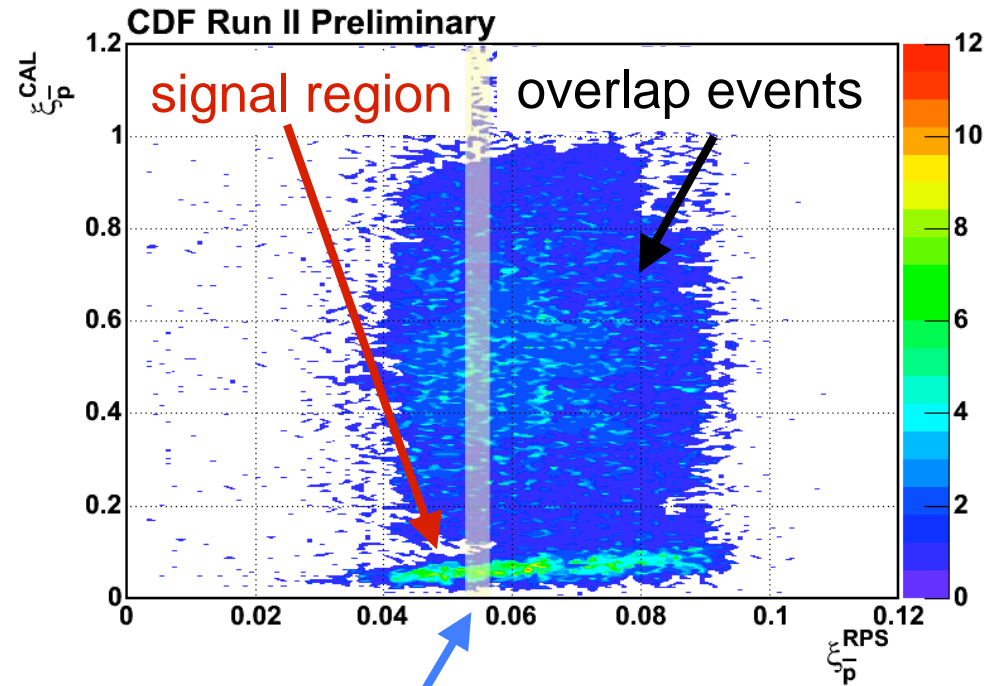
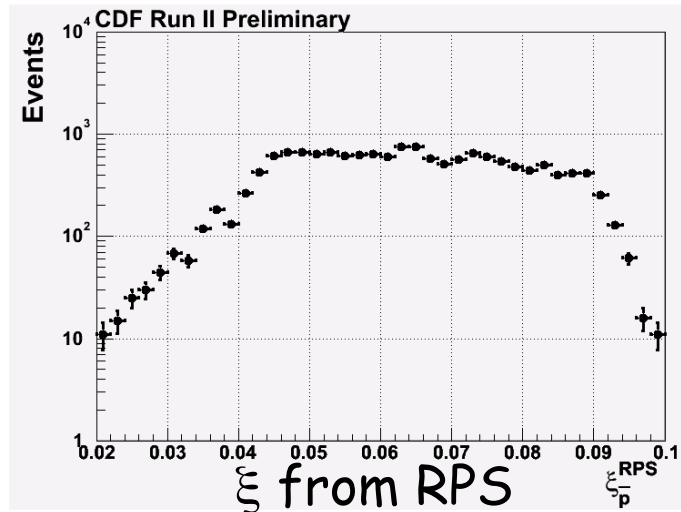

ξ_{p}^{CAL} distribution
for slice of ξ_{p}^{RPS}

$\sigma / \text{mean} \sim 30\%$

Multiple interactions in Run II

- Multiple proton-antiproton interactions spoil diffractive signature

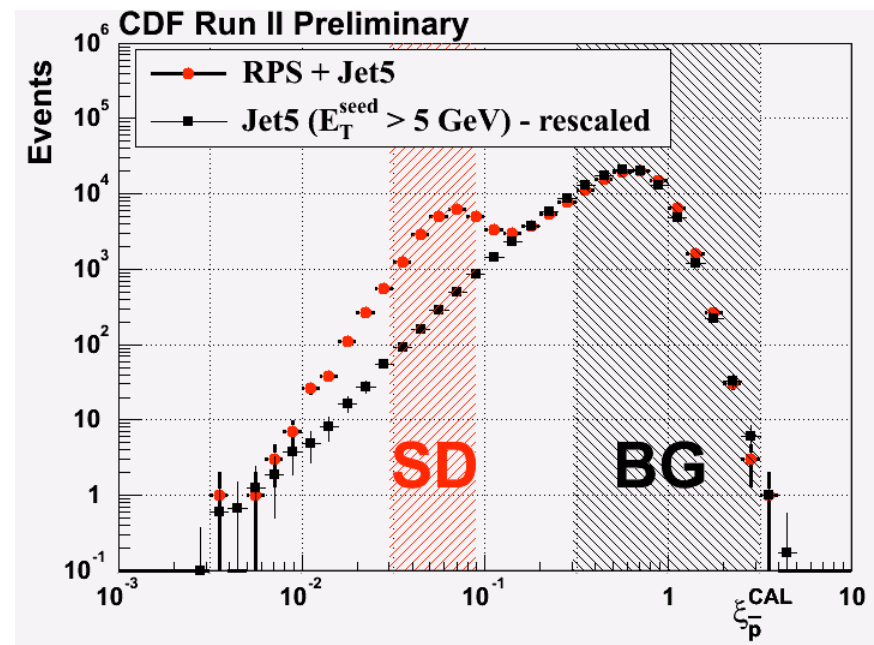
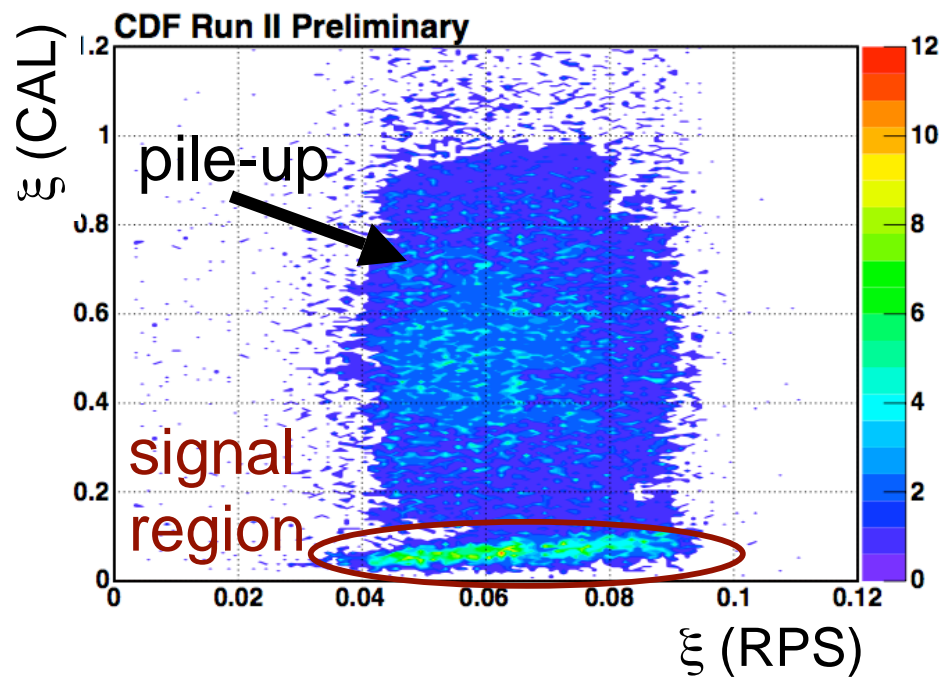

- Measure ξ from calorimeter and from RP tracking
- Reject multiple interactions
 - exclude $\xi > 0.1$ (ND+SD interactions)

Q² dependence

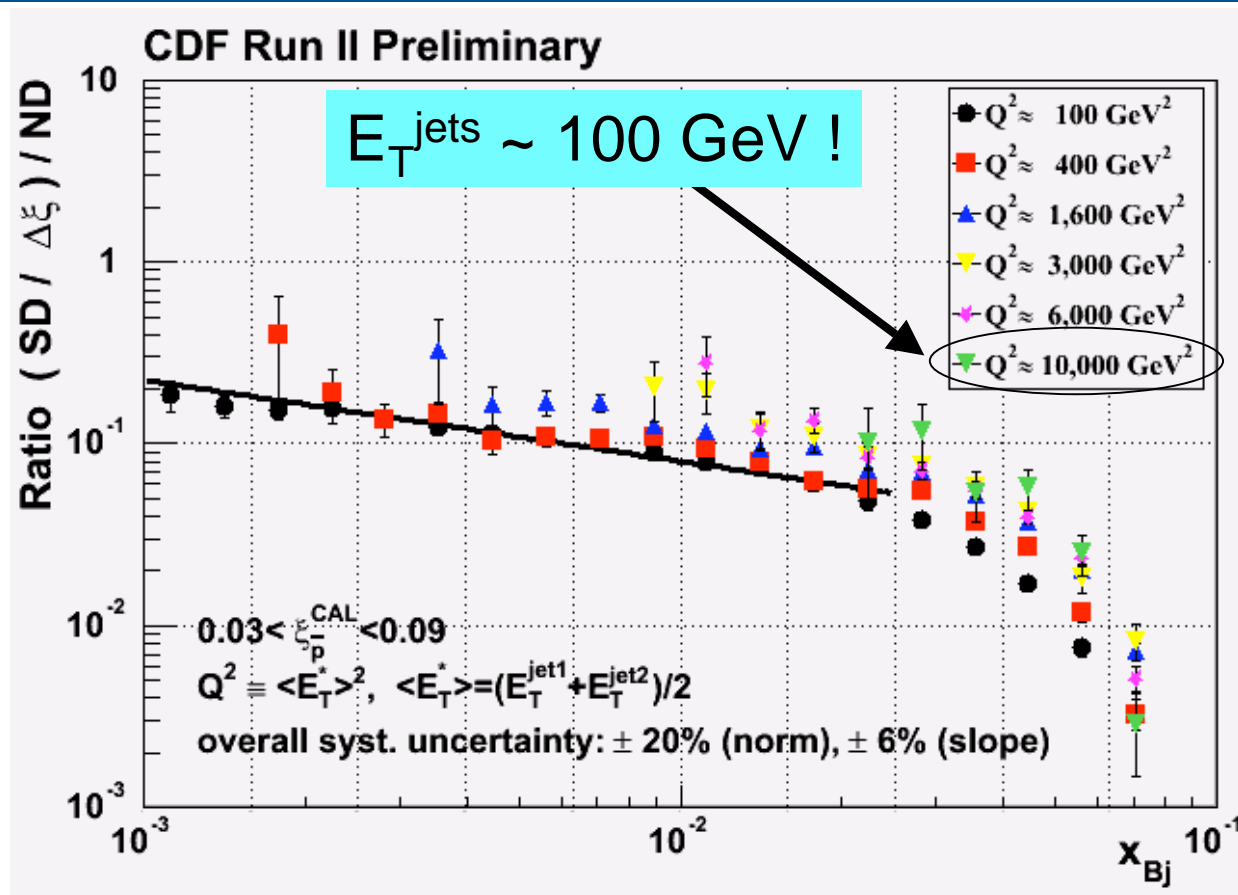

small Q^2 dependence for $100 < Q^2 < 10,000 \text{ GeV}^2$

⇒ Pomeron evolves as proton

RPS dynamic alignment

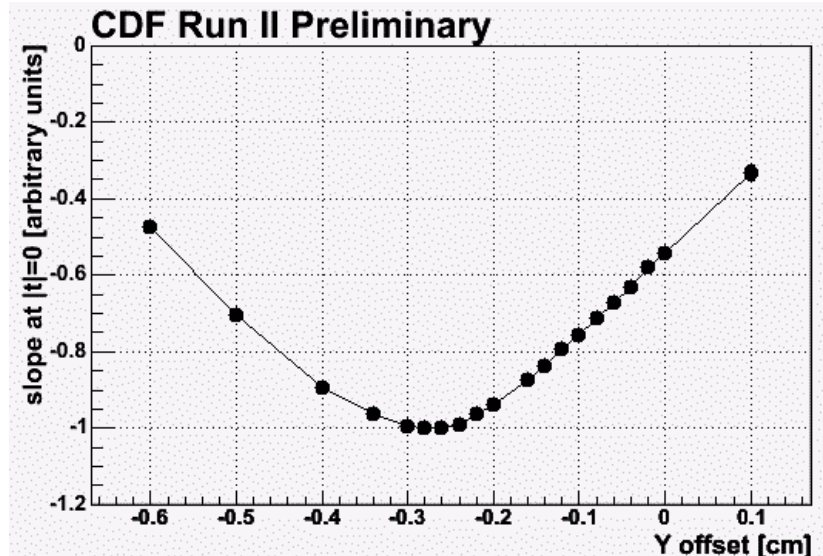

maximize the $|t|$ -slope
(normalized to max slope)
⇒ determine X and Y offsets

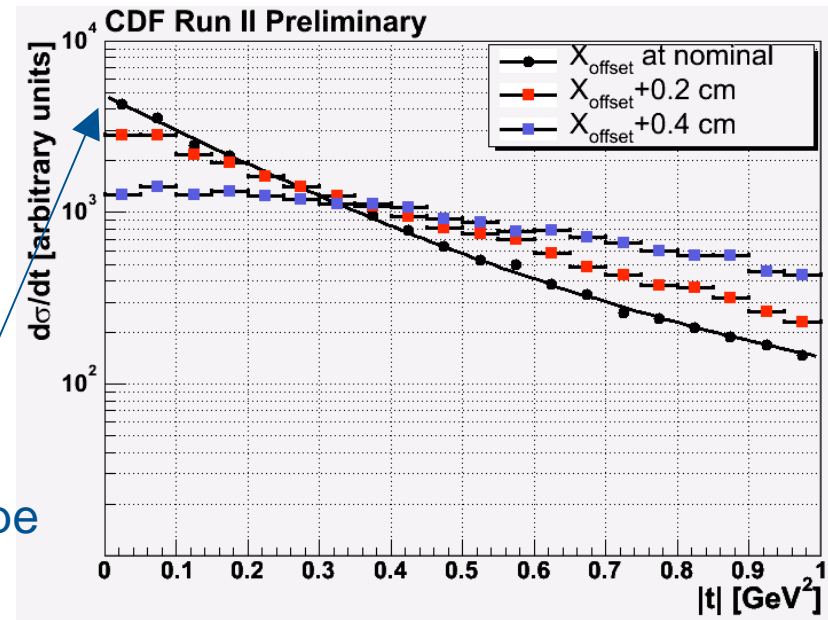
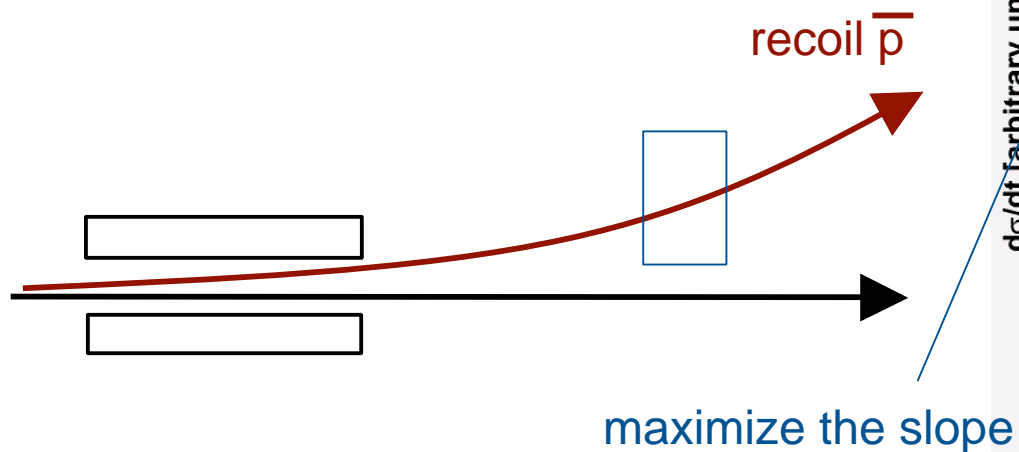

$|t|$ distribution

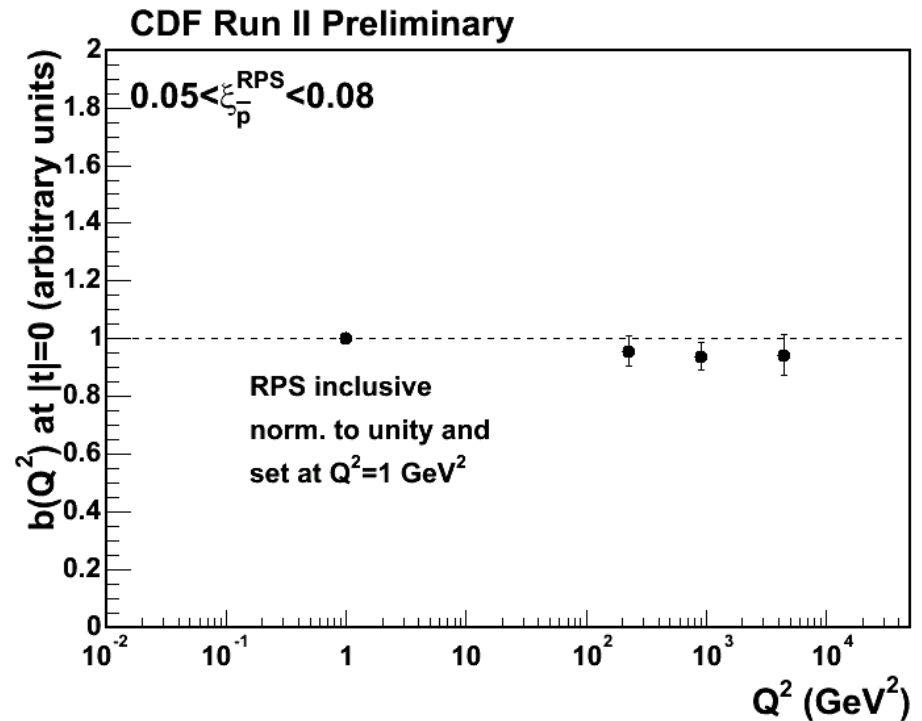
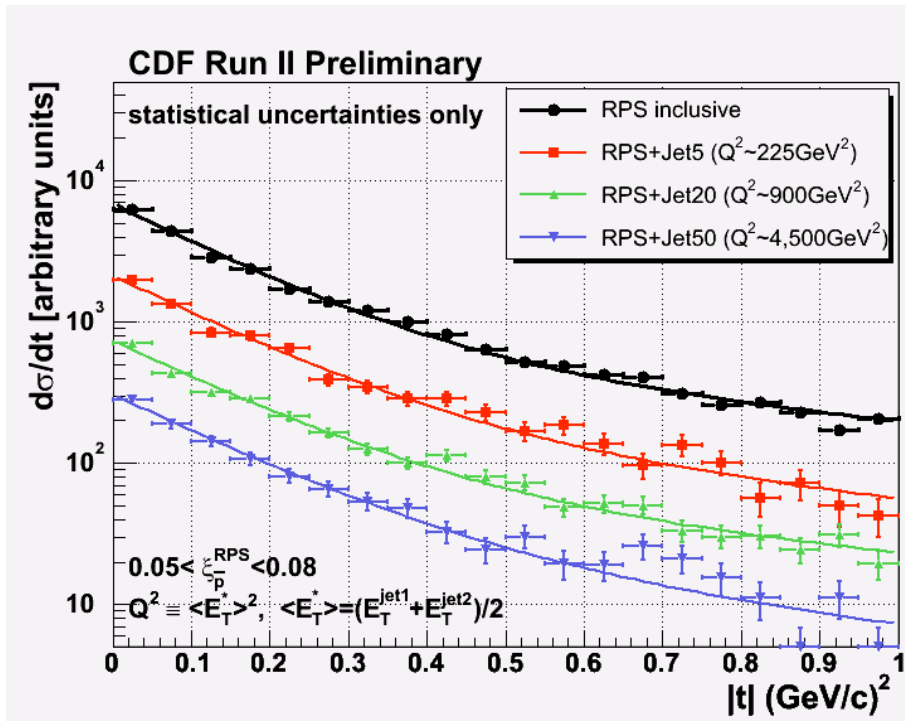

- No diffraction `dips' observed at $|t| < 1$
- Soft and hard diffractive events have the same slope

Diffraction W/Z production

Study W/Z boson production helps to determine the **quark** content of the Pomeron

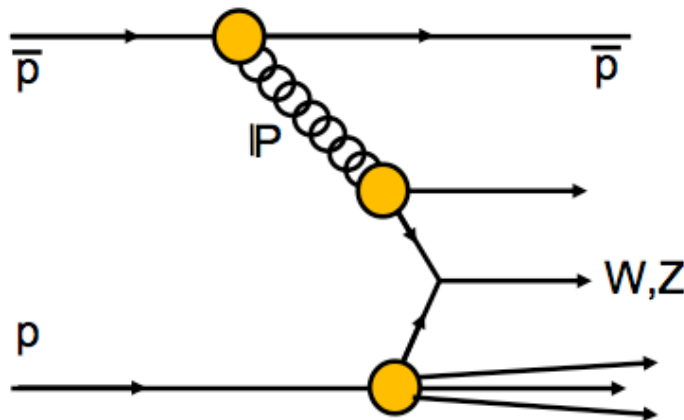

At LO, the W/Z is produced by a **quark** in the Pomeron

or

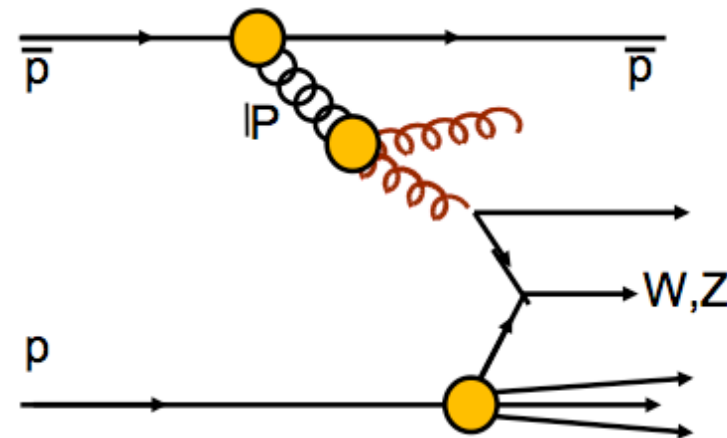

Production by a **gluon** is suppressed by α_s . Can look at additional jet.

Diffractive W/Z production (cont)

- Identify diffractive events using RPS
- Calculate ξ from calorimeter
- In W production, difference $\xi^{cal} - \xi^{RPS}$ is due to missing E_T , and η_ν .

$$\xi^{RP} - \xi^{cal} = \frac{E_T}{\sqrt{s}} e^{-\eta_\nu}$$

- Can estimate:
 - neutrino kinematics
 - W kinematics
 - X_{Bj}
- Next: Determine structure function in diffractive W production

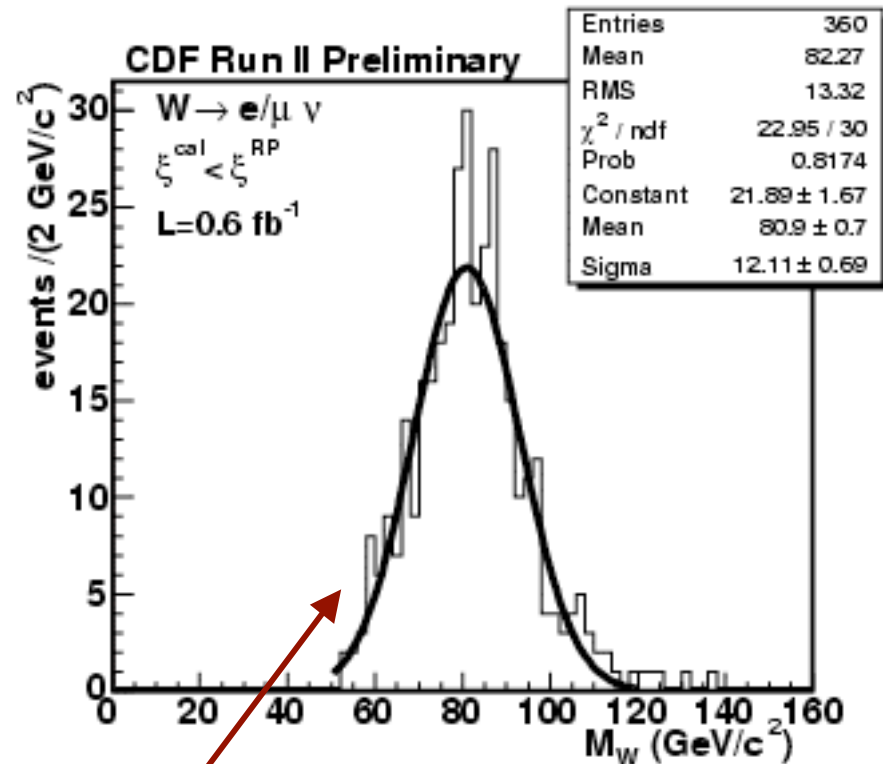

reconstruct W invariant mass

Diffractive W/Z production (cont)

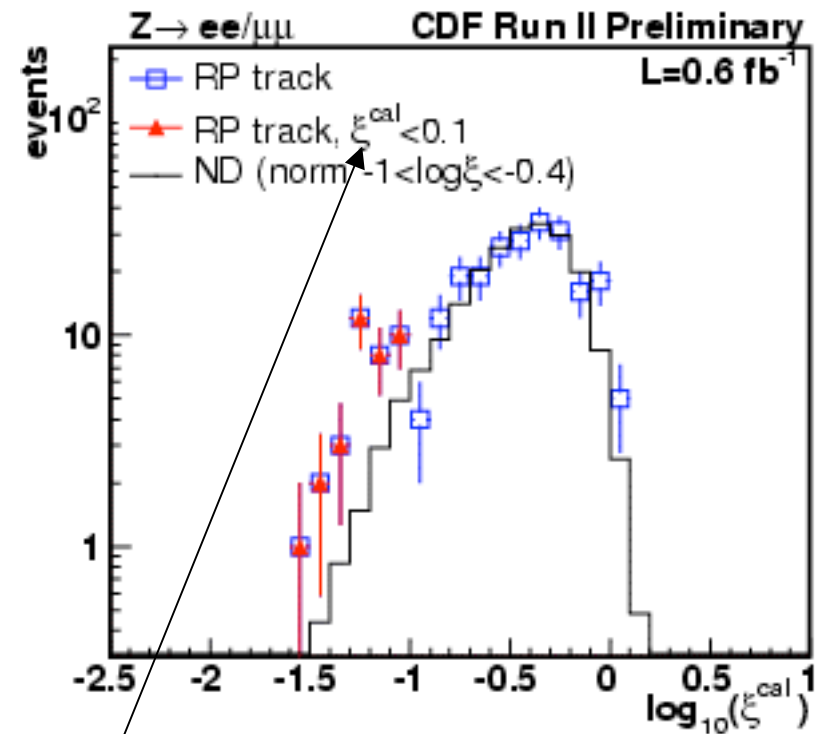
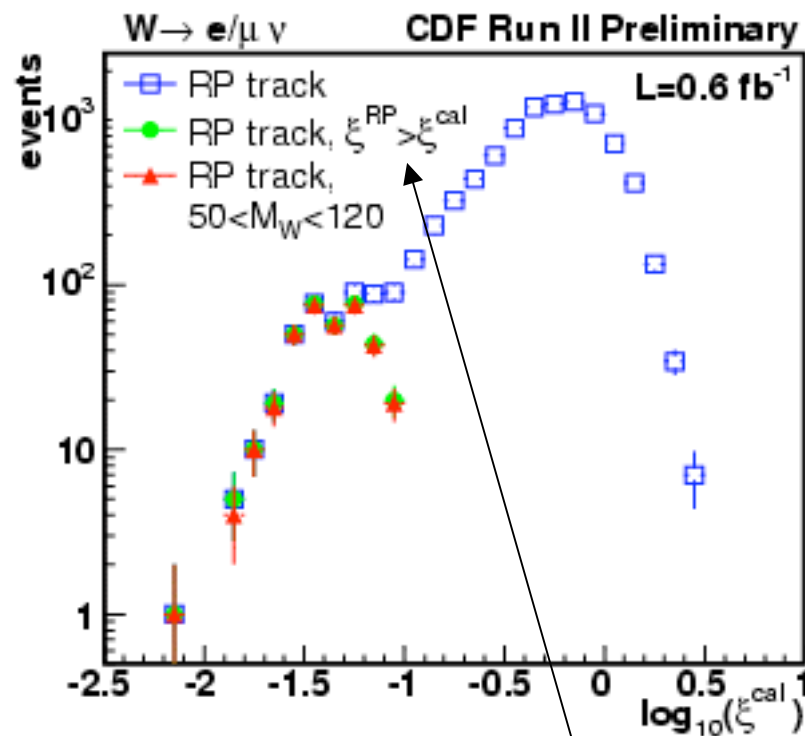

Remove events with non diffractive W/Z production+soft SD interaction

Diffraction W/Z measurement

- Measured fractions:

$$R_W = 0.97 \pm 0.05(\text{stat}) \pm 0.11(\text{syst}) \%$$
$$R_Z = 0.85 \pm 0.20(\text{stat}) \pm 0.11(\text{syst}) \%$$

- Run I diffractive W studies performed with rapidity gap instead of RPS
- CDF: Phys.Rev.Lett. 78,2698(1997)
 - Fraction of events due to SD for $x < 0.1$: **[1.15±0.51(stat)±0.20(syst)]%**
 - Combined with other SD measurements (b-quark,jet), quark-gluon content of the Pomeron is determined: $f=0.54^{+0.16}_{-0.14}$
- D0: Phys.Rev.Lett.B 574,169(2003)
 - Fraction of events with rapidity gap:
 - W: **[0.89^{+0.19}_{-0.17}]%**
 - Z: **[1.44^{+0.61}_{-0.52}]%**
 - [If correction for rapidity gap acceptance is applied...R(W): 5.1%]

Diffraction rates

$$p\bar{p} \rightarrow X + \text{gap}$$

Measured SD/ND fractions at 1.8 TeV

PRL	process	fraction [%]
84 (1997) 2698	W(ev)	1.15 (0.55)
PLB 574 (2003) 169	Z	1.44 (0.60)
84 (1997) 2636	jet-jet	0.75 (0.10)
84 (2000) 232	b	0.62 (0.25)
87 (2001) 241802-1	J/ψ	1.45 (0.25)

W probes quark component ($q\bar{q} \rightarrow W$)

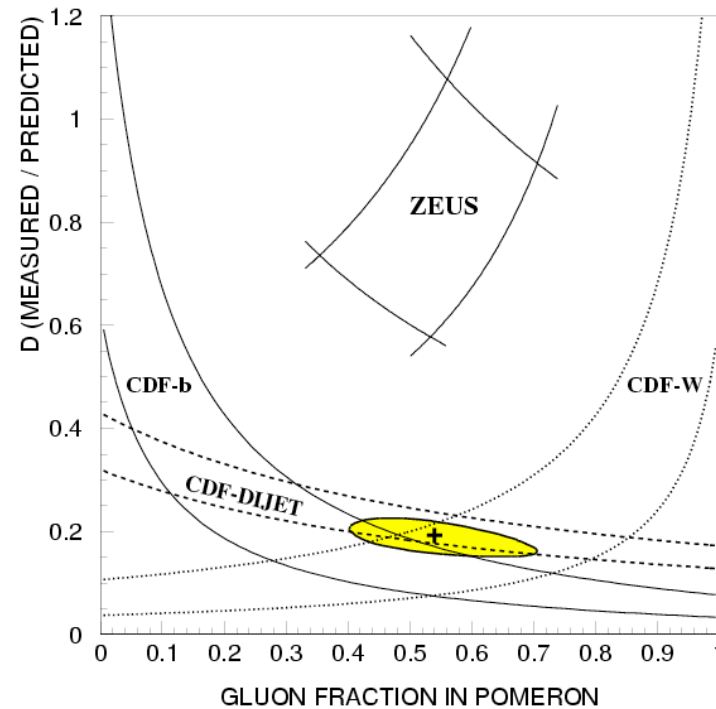

All SD/ND fractions ~ 1%
 Different sensitivities to quark/gluon
 \Rightarrow gluon fraction $f_g = 0.54 (0.15)$

Central gap between forward jets

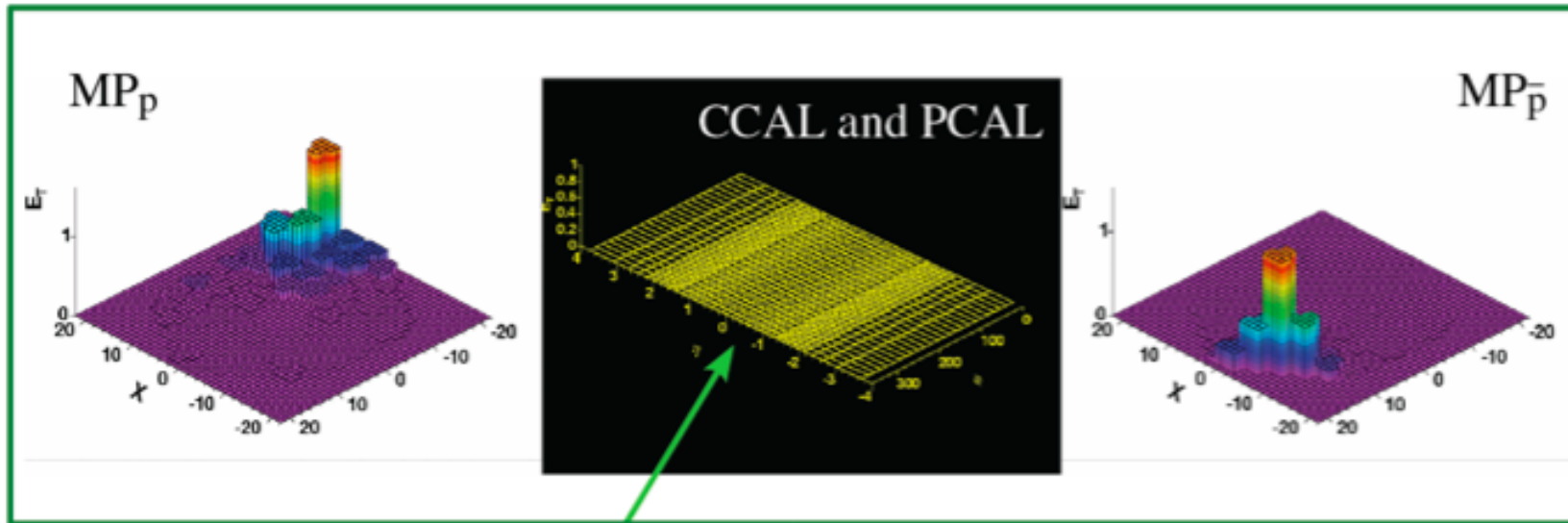

Rapidity gap in Central and Plug calorimeter

- Characterize gap formation
 - fraction of gap events (soft and hard interactions)
 - dependence on gap size
- Mueller-Navelet jets

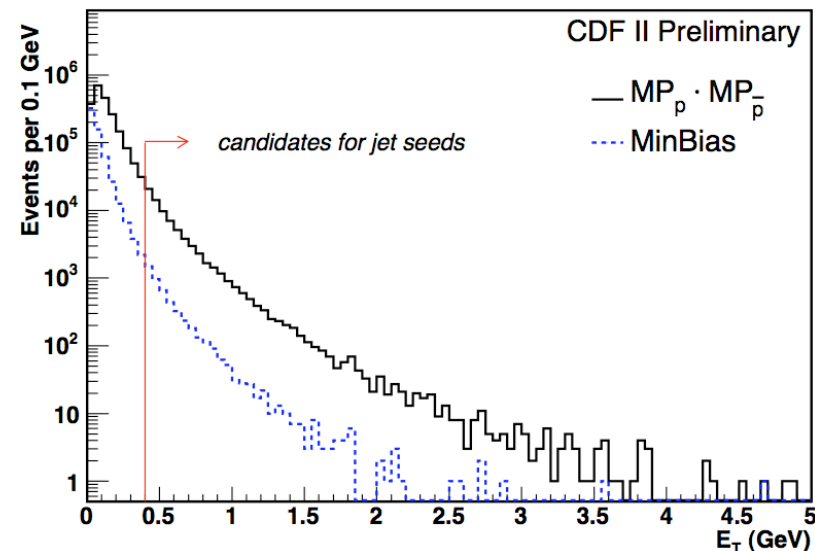

Jet $\Delta\phi$ correlation

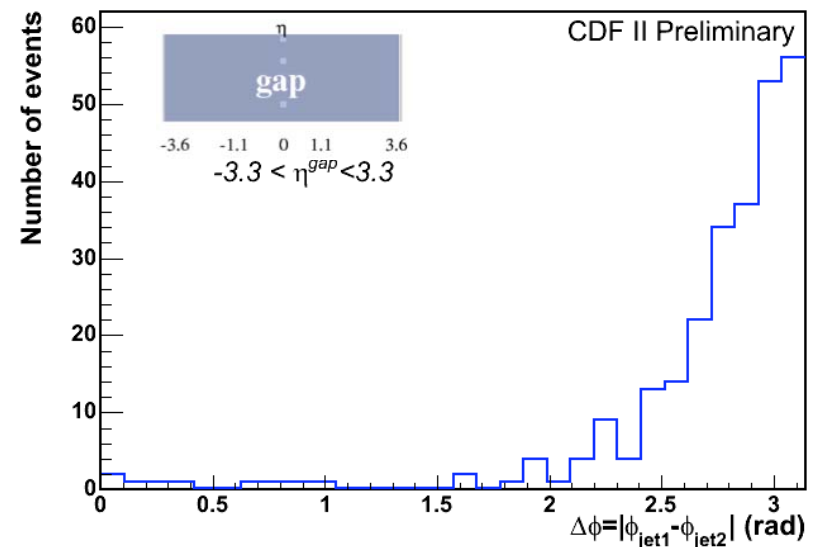
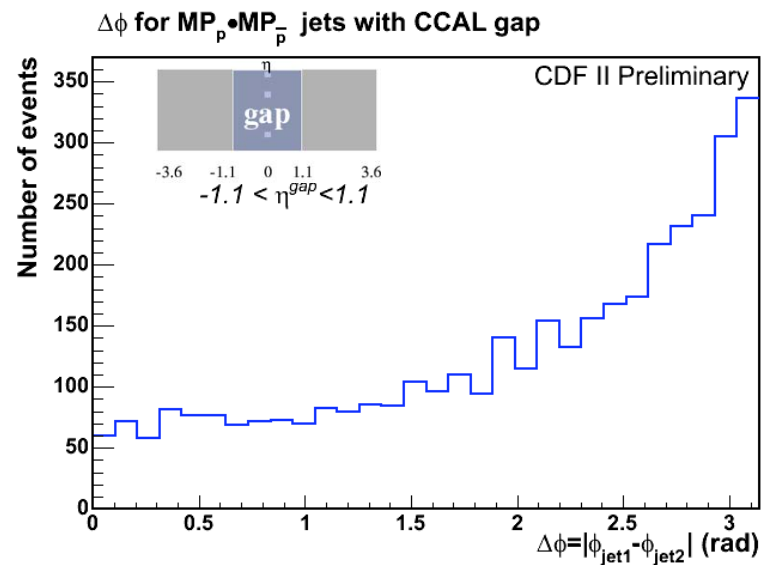
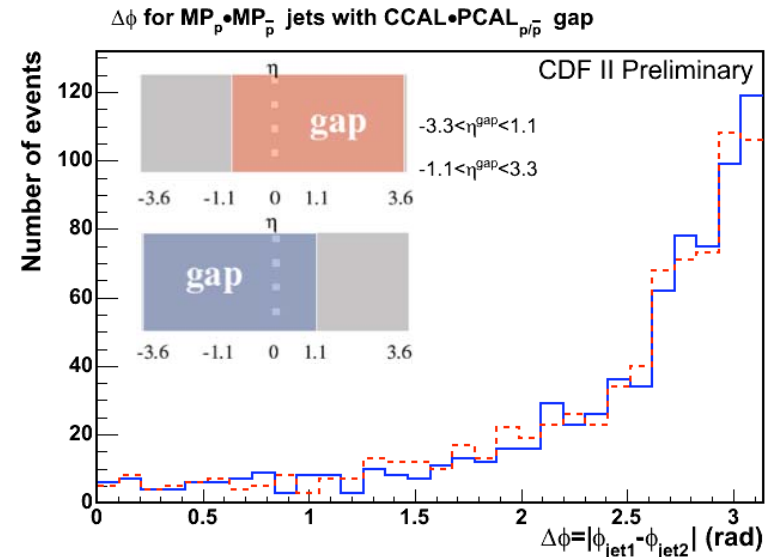
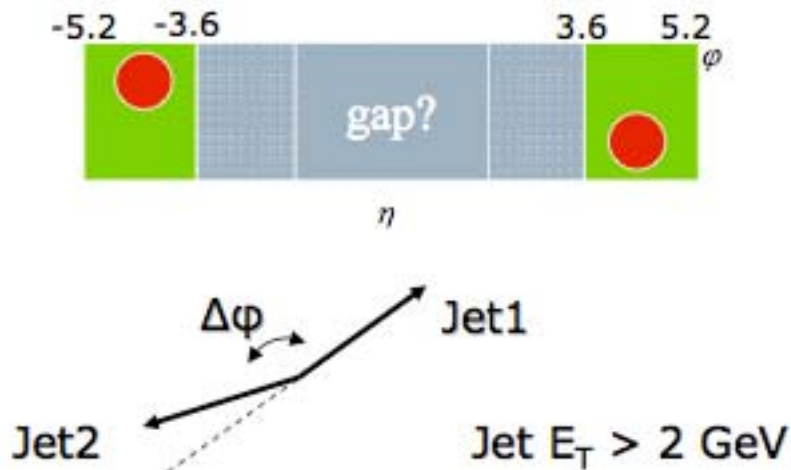

Rapidity gap event fraction

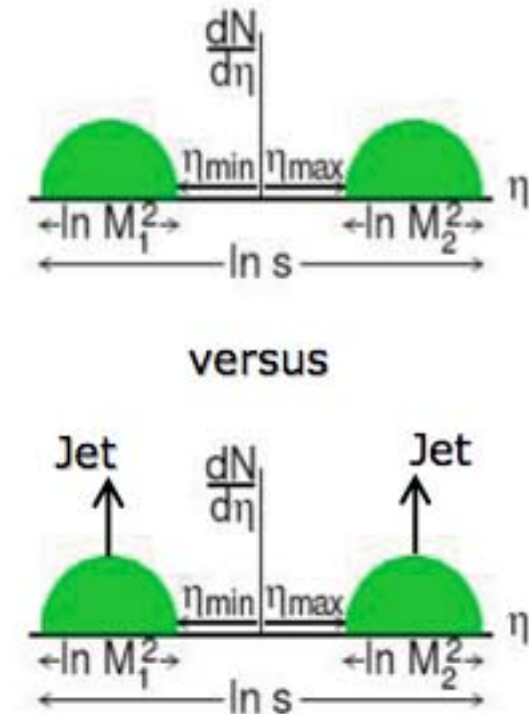
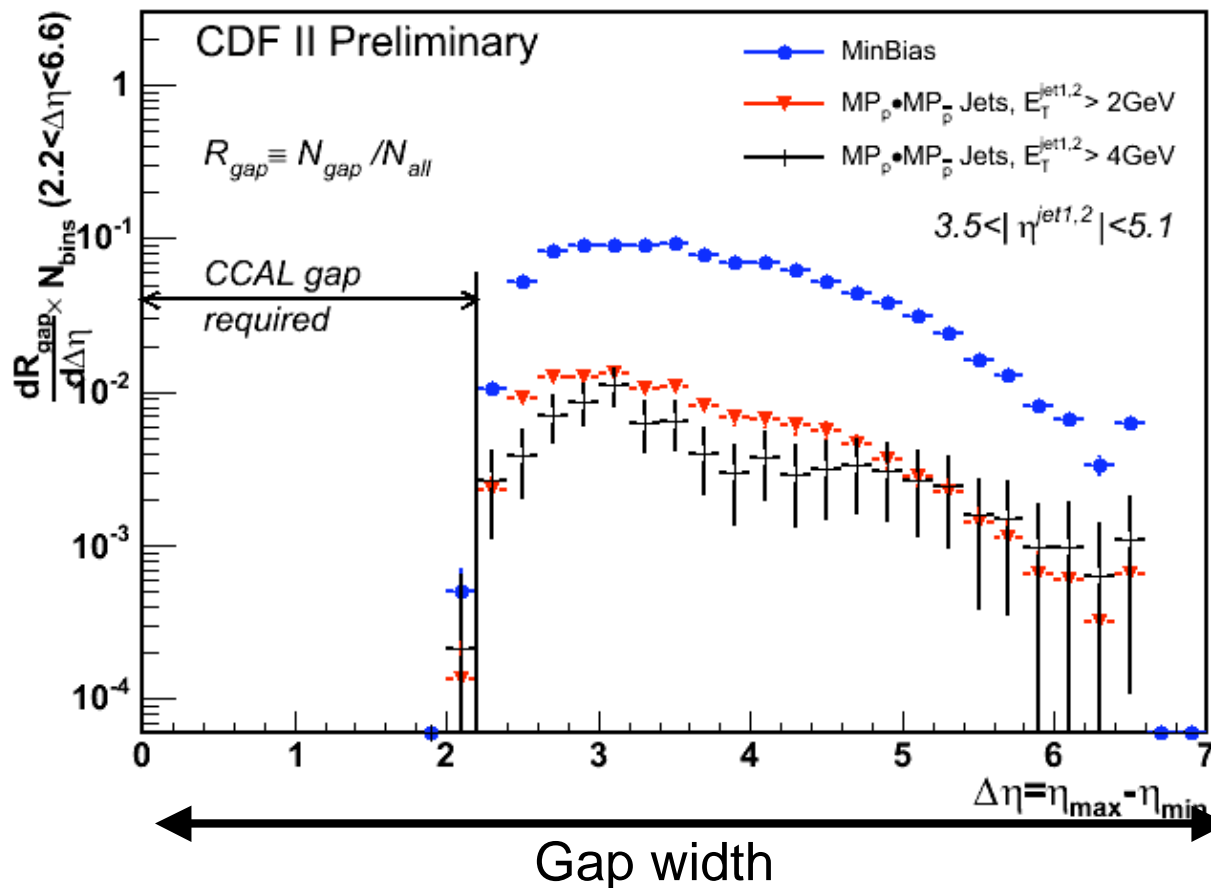

- Event fraction is $\sim 10\%$ in soft events, and $\sim 1\%$ in jet events
- Shapes are similar

Exclusive production

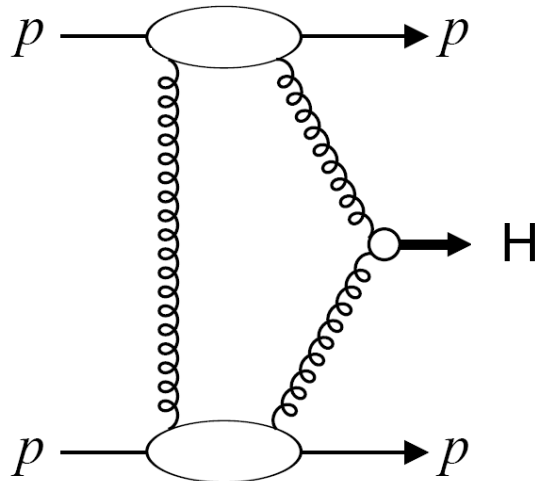

- ✓ clean process
- ✓ exclusive $b\bar{b}$ suppressed

Khoze Martin Ryskin: $\sigma_H(\text{LHC}) \sim 3 \text{ fb}$,
signal/bkg ~ 3 (if $\Delta M_{\text{miss}} = 1 \text{ GeV}$)

Attractive Higgs discovery channel at the LHC

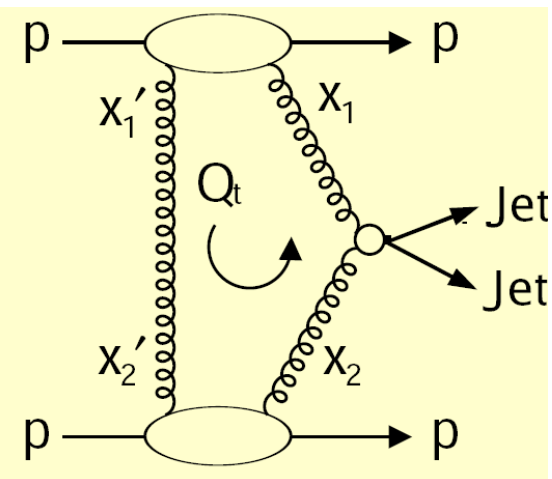

⇒ much larger cross section

Goal:

- measure exclusive dijet production (if it exists)
- test/calibrate Higgs predictions at LHC

Exclusive dijets in Run I

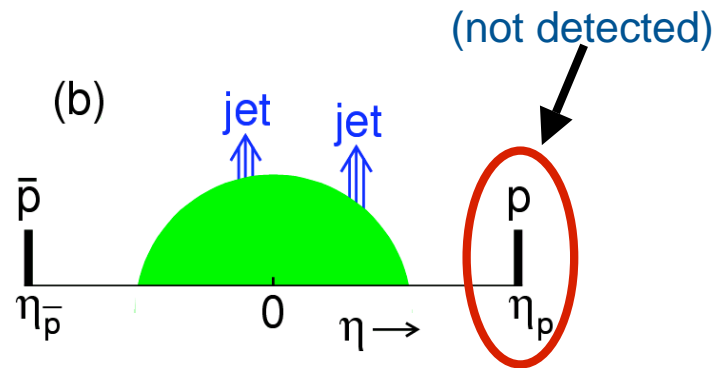

Mass fraction:

$$R_{jj} = \frac{M_{jj}}{M_x}$$

Exclusive dijet limit:

Run I: PRL 85 (2000) 4215

$\Rightarrow \sigma_{jj} \text{ (excl.)} < 3.7 \text{ nb (95\% CL)}$

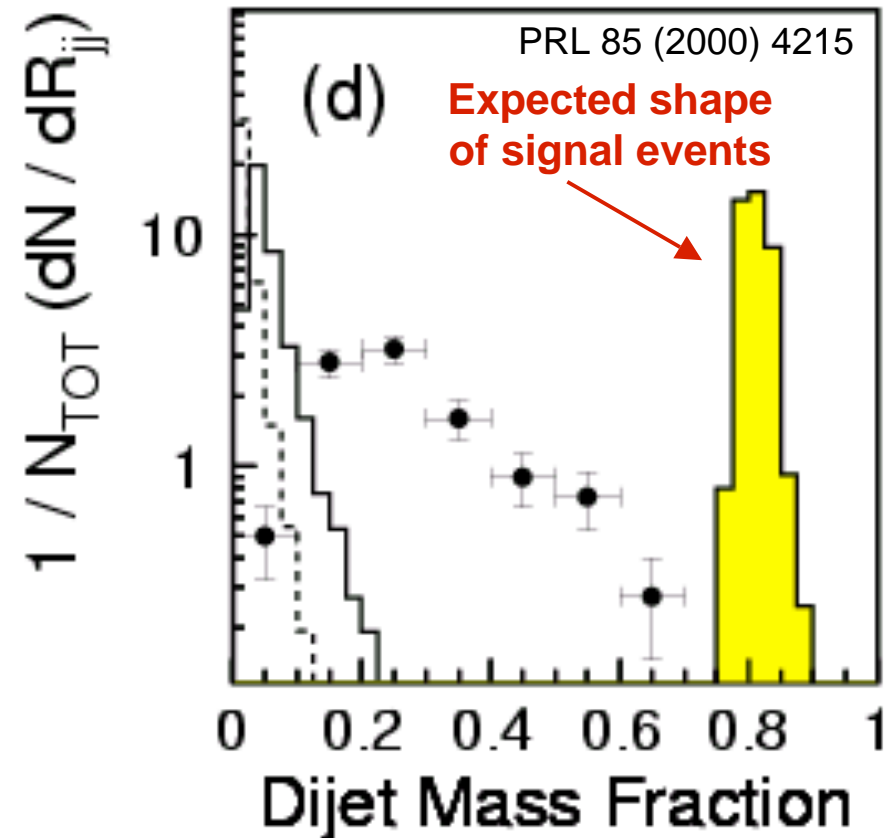

Observation of exclusive dijets

Phys.Rev.D77:052004,2008

Observe excess over
inclusive DPE at large M_{jj}

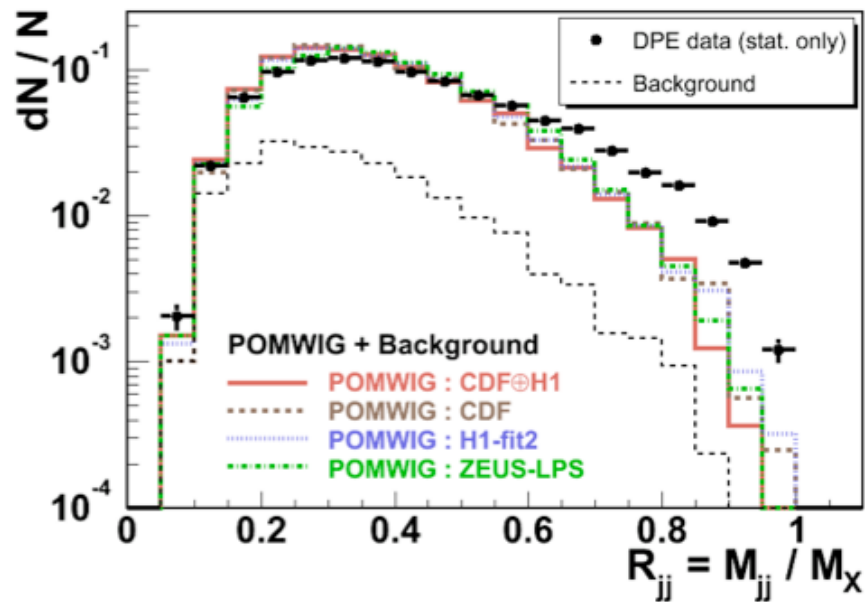

⇒ exclusive signal?

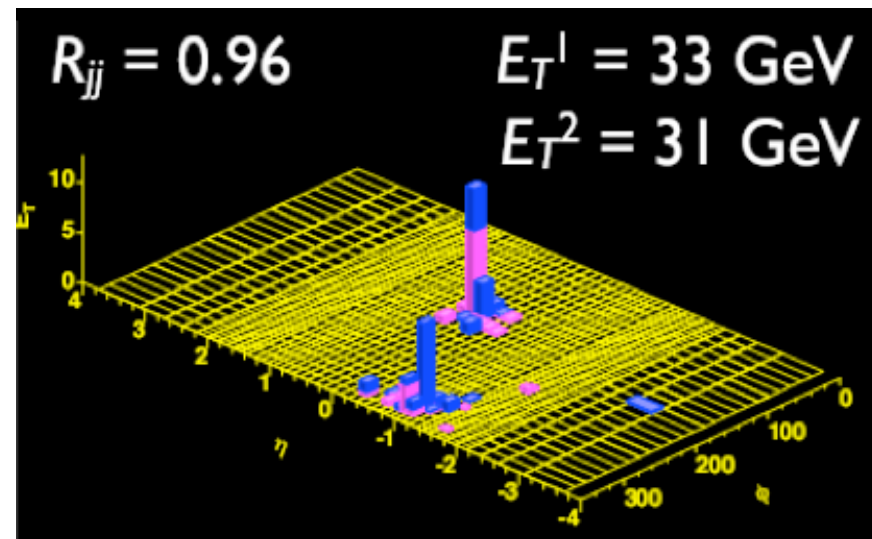
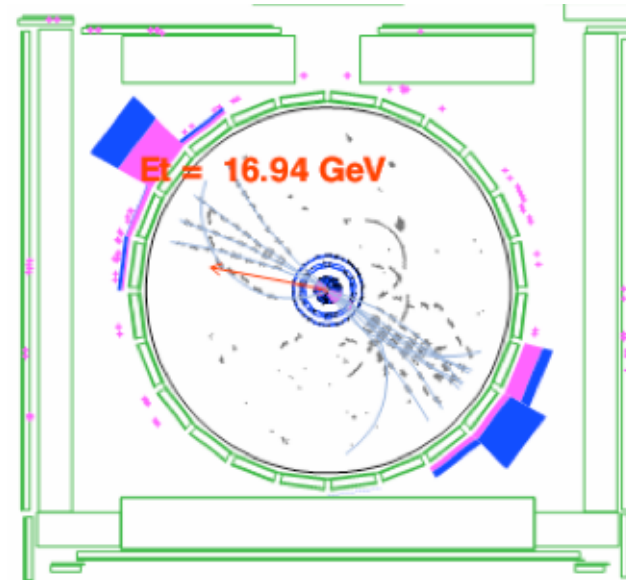

Exclusive dijet cross section

Phys.Rev.D77:052004,2008

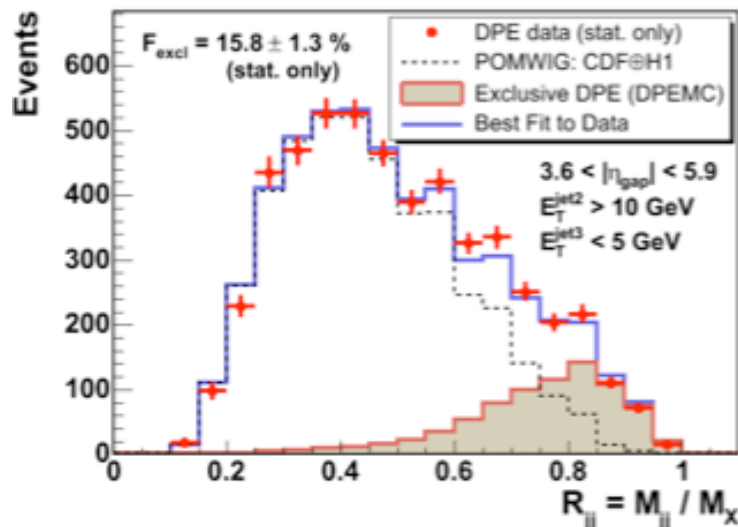
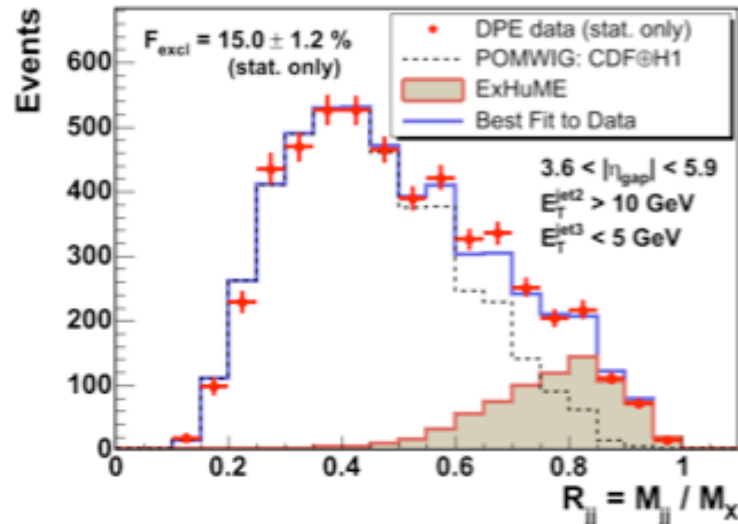

- $R_{||}$ shape described by MC based on two models (ExHuME, DPEMC)
- Cross section agrees with ExHuME
- Data favor KMR model (uncertainty ~factor of 3)

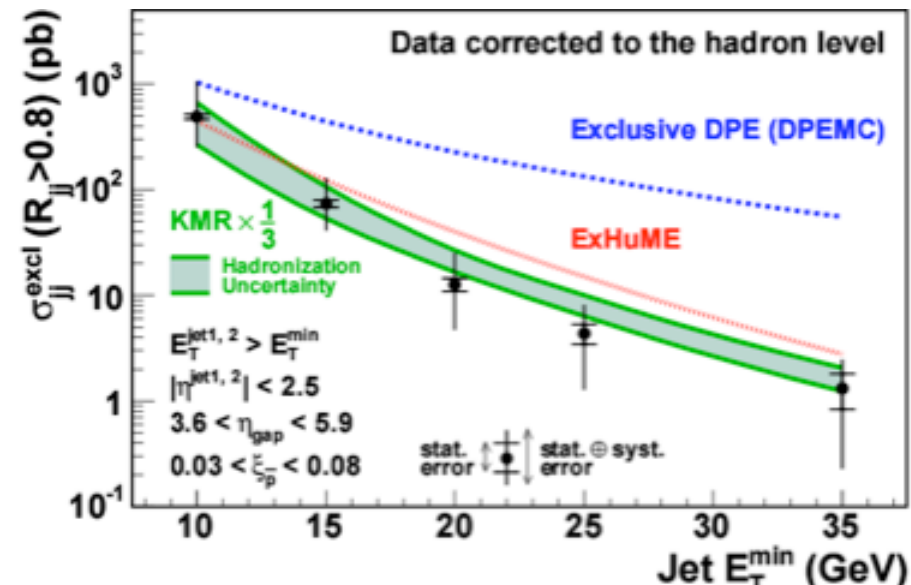

Exclusive cross section

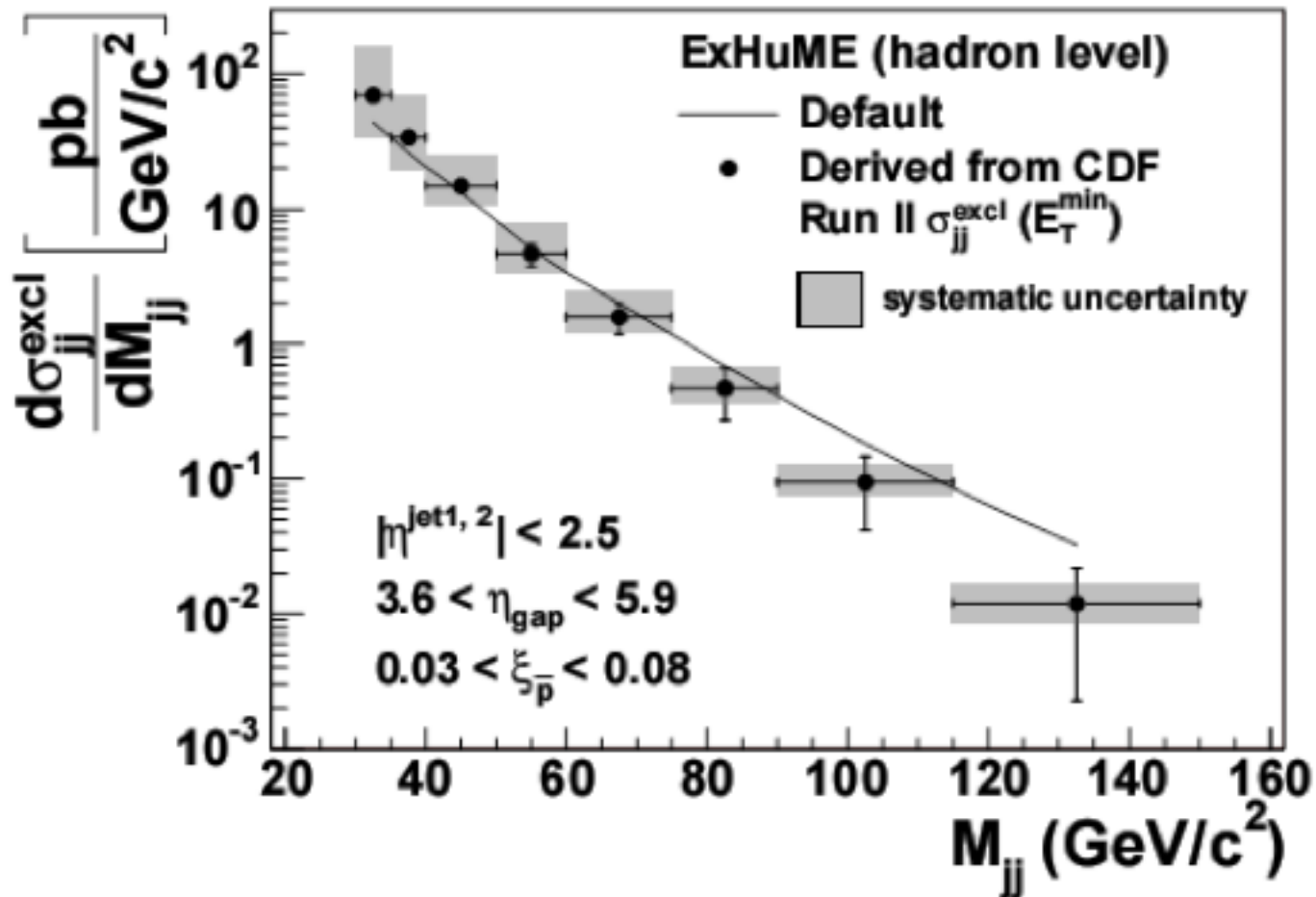

Exclusive $\gamma\gamma$ production

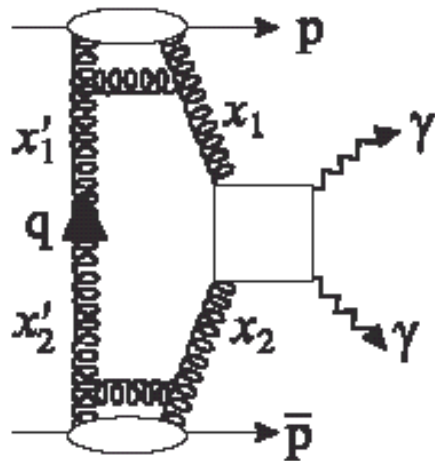

- QCD diagram same as pHp
- smaller cross section than exclusive dijets

$\sim 40 \text{ events/fb}^{-1}$ with $p_T(\gamma) > 5 \text{ GeV}/c$, $|\eta| < 1.0$

the **effective** luminosity must be considered since additional interactions “populate” gaps

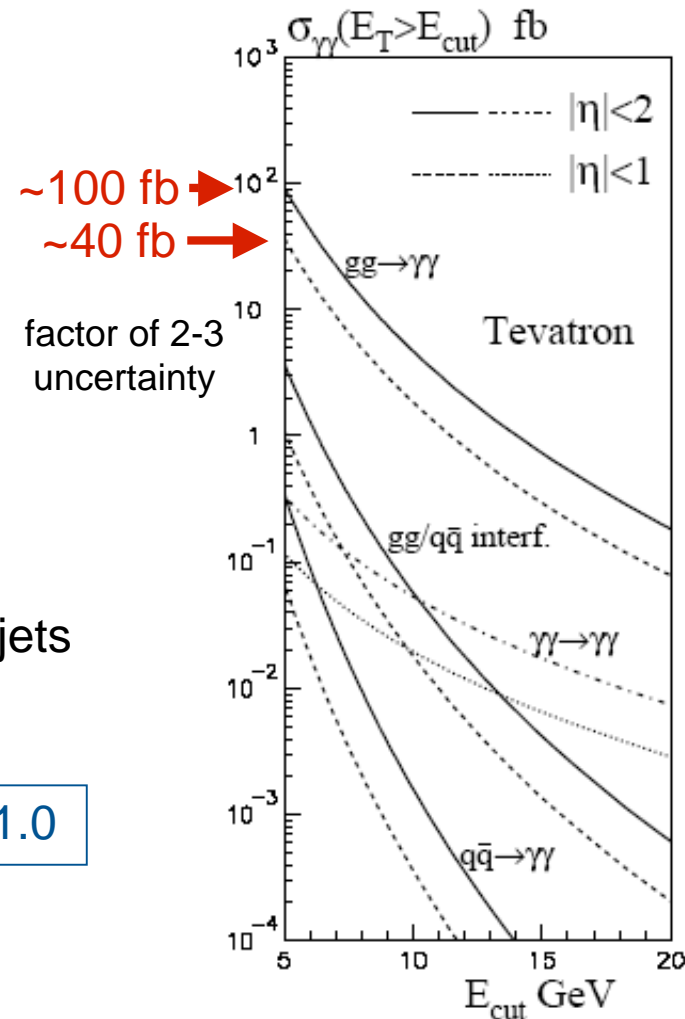

Khoze, Kaidalov, Martin, Ryskin, Stirling, hep-ph/0507040

Exclusive $ee/\gamma\gamma$ search

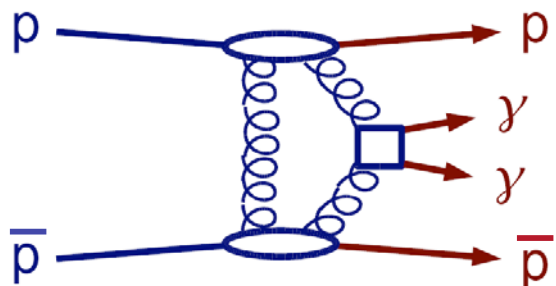

$$p\bar{p} \rightarrow p + \gamma\gamma + \bar{p}$$

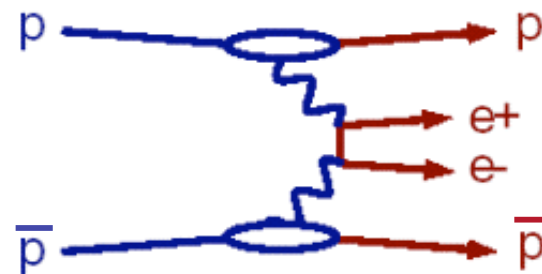

QED process: cross-check to exclusive $\gamma\gamma$

- ✓ do not detect (anti)proton
- ✓ require 2 EM showers ($E_T > 5$ GeV, $|\eta| < 2$)
- ✓ veto all calorimetry and BSCs except 2 EM showers
- ✓ $L \sim 530$ pb $^{-1}$ delivered ($L_{\text{effective}} = 46$ pb $^{-1}$)

⇒ 19 events have 2 EM showers + "nothing"

caveat: "nothing" above threshold

Exclusive ee search

Phys.Rev.Lett.98:112001,2007

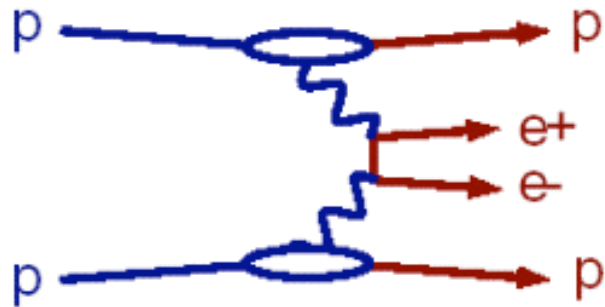

control sample for $\gamma\gamma$ search

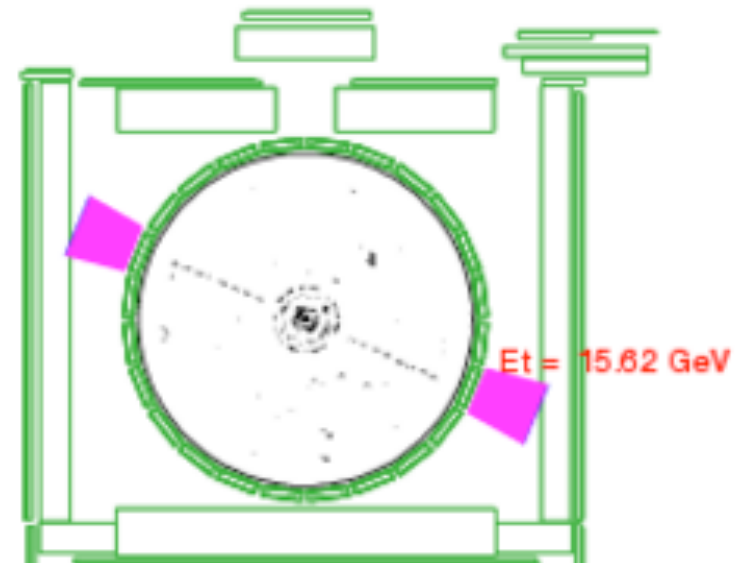

\Rightarrow 16 candidate events found
background: 1.9 ± 0.3 events

$$\sigma_{MEASURED} = 1.6^{+0.5}_{-0.3} \text{ (stat)} \pm 0.3 \text{ (sys) pb}$$

good agreement with LPAIR:

$$\sigma_{LPAIR} = 1.711 \pm 0.008 \text{ pb}$$

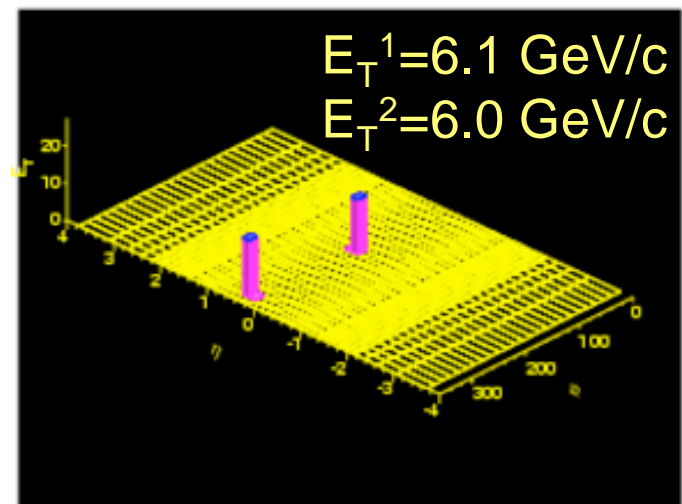

Exclusive $\gamma\gamma$ search

Phys.Rev.Lett.99:242002,2007

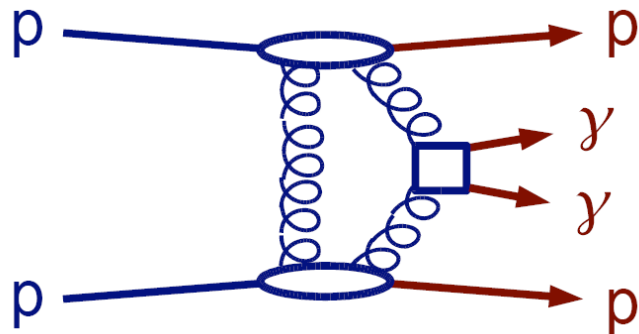

\Rightarrow 3 candidate events found
background: $0.0^{+0.2}_{-0.0}$ events

$$\sigma_{\text{measured}} < 410 \text{ fb}$$

good agreement with KMR:

$$\sigma_{\text{KMR}} = 36 \pm {}^{72}_{24} \text{ (x2-3) fb}$$

$\Rightarrow \sigma_H \sim 10 \text{ fb}$ (if H exists)
within a factor $\sim 2-3$, higher in MSSM

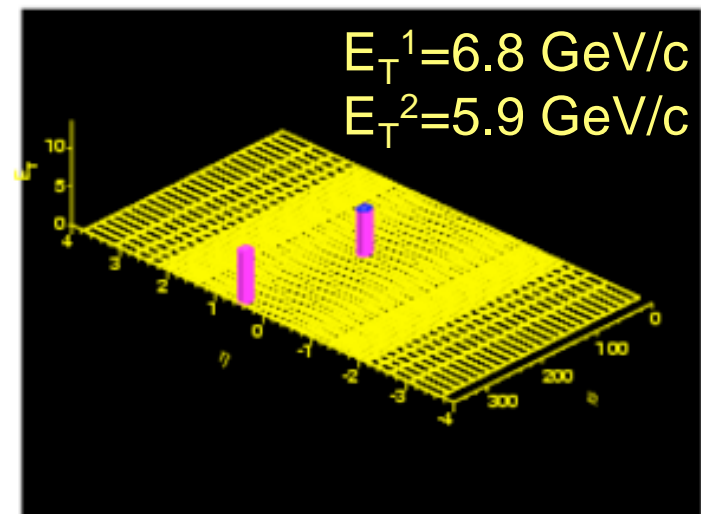
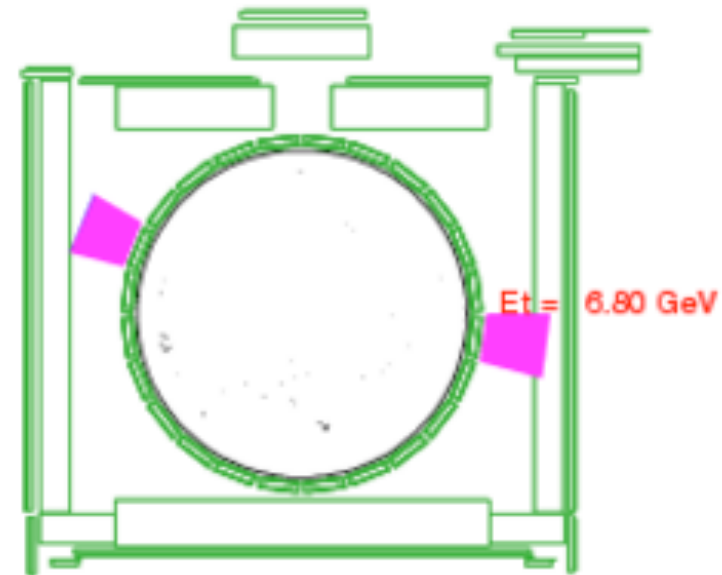

Conclusions

- CDF diffractive program continuing the improvement of understanding of diffractive processes
- Comparison of diffractive and non-diffractive processes
- Characterization of gap formation (survival probability)
- Measurements of exclusive production important to calibrate predictions for exclusive Higgs production at LHC

backup

Rapidity gap fraction vs gap width

- Soft double diffraction
- No hard scattering required
- Look for rapidity gaps

